

标记	文件号	修改内容	签名	日期

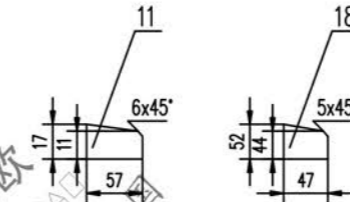
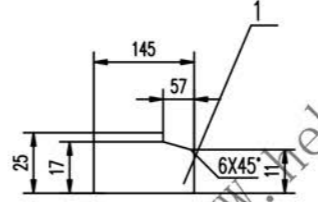
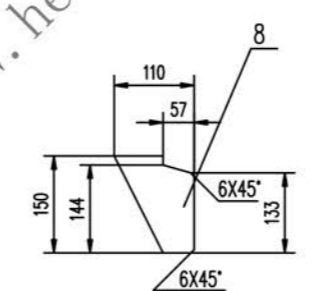
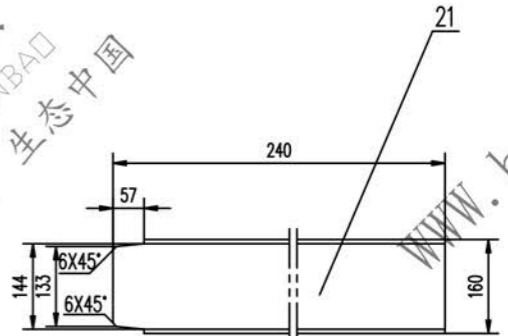
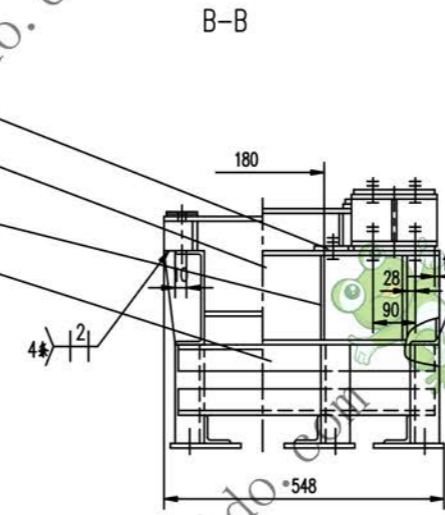
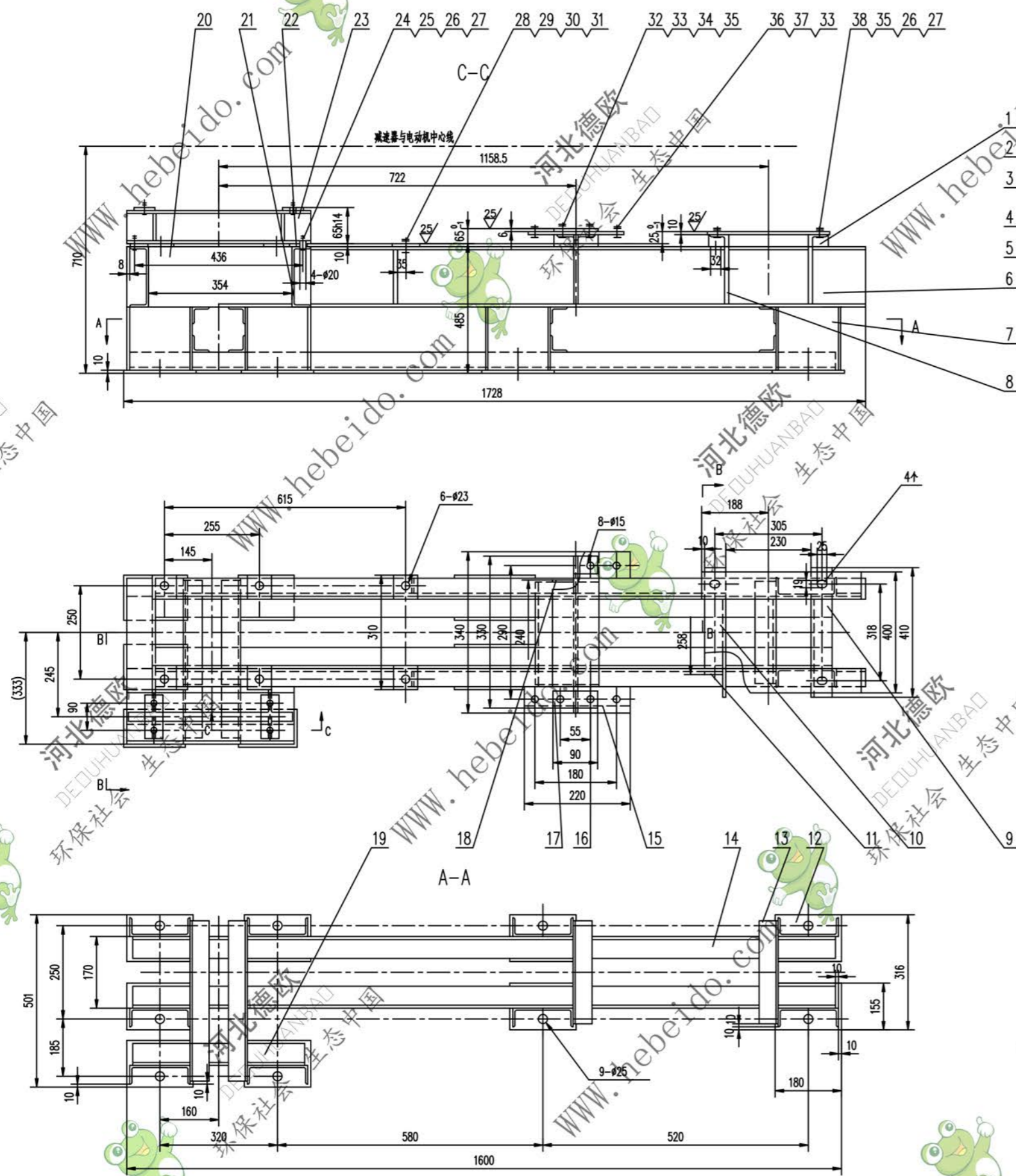

- 技术要求
1. 未注焊缝为连续角焊, 焊缝高度为被焊件最小厚度或为对接。
  2. 所有下料端面垂直度为  $\frac{1}{100}$ 。
  3. 所有孔表面圆度为  $\frac{1}{100}$ 。
  4. 圆角过渡后焊接。
  5. 未注除锈按GB10595-89中3.11的规定。

38	GB5784-86	螺栓 M16X95	4	—	0.183	0.732
37	GB93-87	垫圈 12	4	—	0.005	0.020
36	GB5784-86	螺栓 M12X35	4	—	0.068	0.272
35	GB97.1-85	垫圈 12	4	—	0.005	0.020
34	GB852-88	垫圈 12	4	—	0.004	0.016
33	GB41-86	螺母 M12	4	—	0.016	0.192
32	GB5784-86	螺栓 M12X75	4	—	0.085	0.340
31	GB97.1-85	垫圈 20	6	—	0.017	0.102
30	GB853-88	垫圈 20	6	—	0.047	0.282
29	GB41-86	螺母 M20	12	—	0.062	0.744
28	GB5780-86	螺栓 M20X110	6	—	0.324	1.944
27	GB97.1-85	垫圈 16	8	—	0.011	0.088
26	GB853-88	垫圈 16	8	—	0.028	0.224
25	GB41-86	螺母 M16	16	—	0.034	0.544
24	GB5784-86	螺栓 M16X75	8	—	0.139	1.112
23	J521ZIN 161-1	支架	1	—	19.09	19.09
22	—	钢板 (10)X65X160	2	Q235-A	0.816	1.632
21	—	槽钢 160X63X6.5	1	Q235-A	4.169	4.169
20	—	槽钢 160X63X6.5-35	1	Q235-A	6.272	6.272
19	—	角钢 50X50X5-470	1	Q235-A	1.772	1.772
18	—	钢板 $\delta 8$	4	Q235-A	0.176	0.704
17	—	钢板 (6)X40X90	2	Q235-A	0.170	0.340
16	—	工字钢 200X100X7-330	1	Q235-A	9.207	9.207
15	—	钢板 8X50X220	2	Q235-A	0.691	1.382
14	—	角钢 50X50X5-1560	2	Q235-A	5.881	11.76
13	—	角钢 50X50X5-276	4	Q235-A	1.041	4.164
12	—	钢板 10X130X180	9	Q235-A	1.837	16.53
11	—	钢板 $\delta 8$	2	Q235-A	0.060	0.120
10	—	槽钢 160X63X6.5-410	2	Q235-A	7.064	14.13
9	—	钢板 (10)X90X455	2	Q235-A	3.215	6.430
8	—	钢板 $\delta 8$	4	Q235-A	0.728	2.912
7	—	槽钢 160X63X6.5-305	9	Q235-A	5.255	47.30
6	—	槽钢 160X63X6.5-1655	2	Q235-A	28.60	57.20
5	—	角钢 50X50X5-461	4	Q235-A	1.746	6.984
4	—	钢板 $\delta 8$	9	Q235-A	0.475	4.275
3	—	槽钢 160X63X6.5-481	1	Q235-A	8.322	8.322
2	—	槽钢 (10)X80X80	6	Q235-A	0.502	3.012
1	—	钢板 $\delta 8$	2	Q235-A	0.219	0.438

序号	代号	名称	数量	材料	单重	总重	附注